

Power Factor Correction Systems

SCHRACK
TECHNIK

Power Factor Correction

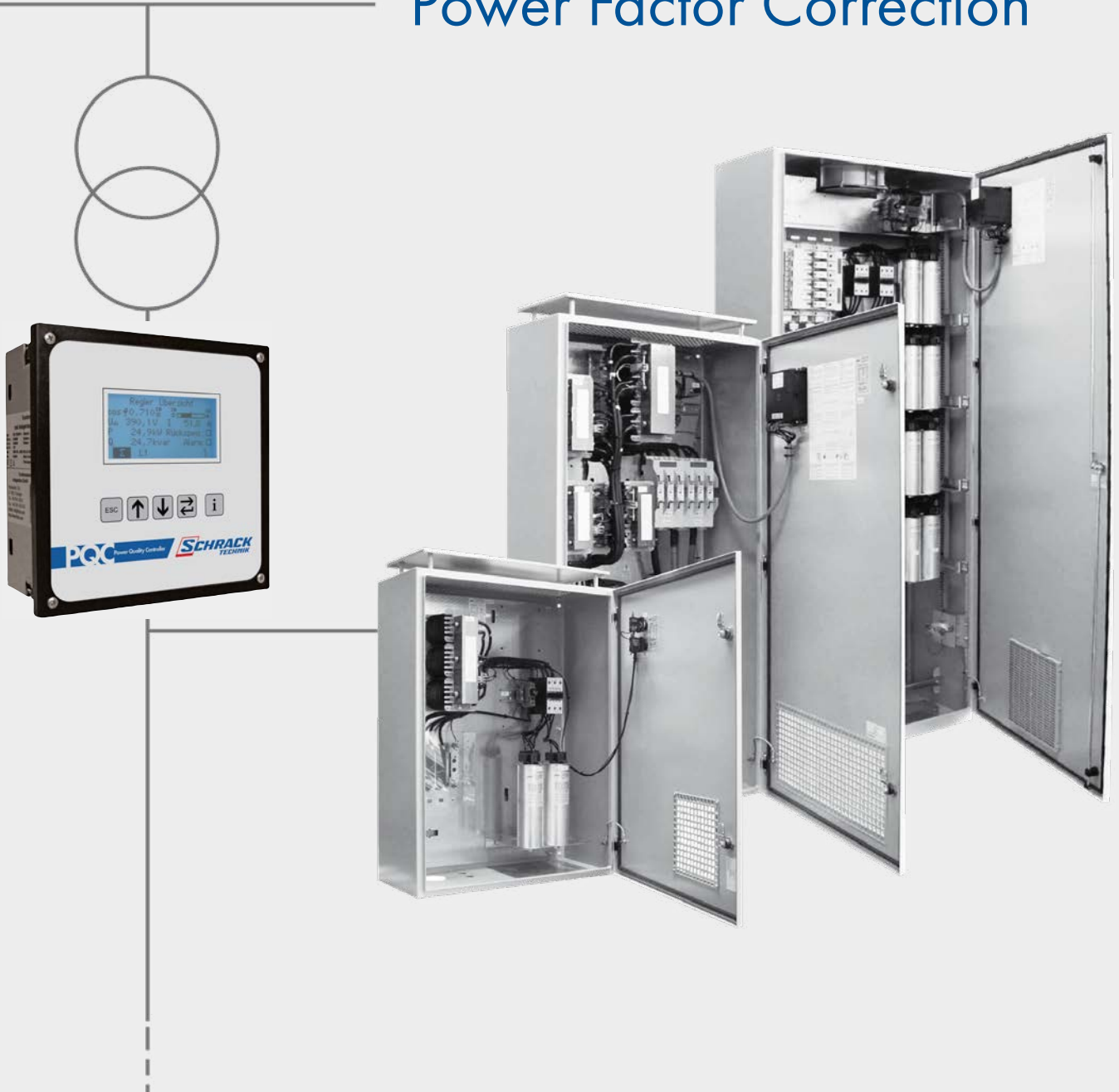

- ✓ Commissioning and Maintenance
- ✓ Assembly instructions

Contents

Commissioning and Maintenance

– System location – correct installation, ingress protection and room temperature	3
– Fuses and cables – power supply cable cross section and rated current of main fuse	3
– Cable connections – connecting the main power supply cable	4
– Current transformer – selection, correct arrangement and connections	4
– Reactive power control relays: RM 2106, RM 2112 and PQC – automatic detection of connection, switching sequence, etc.	5
– Commissioning – switching power on and checking system functions	6
– Operation and maintenance – monitoring of fuses, contactors, screwed connections, etc.	6
– Troubleshooting – a tabular guide to rectifying any problems arising during commissioning	7
– EC Declaration of Conformity – LSFC, LSK	8

Assembly instructions

– Control cabinets	9
– Power loss	9
– Construction of power factor correction systems with C Modules	9
– Complete power factor control relay packages (STR-...)	10
– Capacitor modules, capacitor/reactor modules	10
– Installation of power factor correction systems for supply voltages > 400 V	10
– Circuit diagrams	11

General

SCHRACK power factor correction systems are prewired, and before they leave the factory they undergo a thorough individual inspection to verify the good working order of all components.

Before starting up the system, it is only necessary to connect the power supply and the cabling to the current transformer.

Note! The current transformer itself is not included in the scope of supply for power factor correction systems.

The reactive power control relay must be set according to the separate operating manual supplied with the instrument.

Questions that may arise concerning the wiring and commissioning of the system are treated in detail in these instructions.

Safety instructions

Caution! Dangerous voltages are present inside the cabinet. Every operation that involves opening the door may therefore only be made by appropriately qualified technicians.

The installation of the power factor correction system, the verification of its good working order and any actions taken to rectify faults may only be carried out by appropriately qualified specialists who have received instruction on the electrical hazards involved.

All other actions can be carried out by persons who have familiarized themselves with these instructions and the operating manual for the reactive power control relay and who then follow them at all times.

- These instructions and the operating manual for the reactive power control relay must be read through carefully before the system is installed, connected up and commissioned.
- The power factor correction system must always be earthed.
- Do not install the system near to any liquids, and do not expose it to an excessively humid atmosphere.
- If the power factor correction system is visibly damaged, it must not be installed, connected up or commissioned.
- Do not cover the ventilation grilles.
- Do not expose the system to direct sunlight or install it near to a source of heat.
- If the system is not put into service immediately, it must be stored in a dry location at a temperature between - 20 °C and + 60 °C.
- Please observe all current statutory regulations governing the recycling of the packaging materials.

System location

Standard versions of SCHRACK power factor correction systems are constructed with ingress protection to EN 60529 ranging from IP20 to IP43 (in some cases IP20 and IP54 for small series LSK systems) and are designed for operation in dry rooms. The ambient temperature must not exceed 40 °C. Openings are provided in the enclosures for ventilation, and these must not be covered, as this would inhibit the free circulation of air. Many versions are fitted with fan/fILTER units. If there is any tendency for hot air to accumulate in the room where the system is installed, it must be ensured that the room is adequately ventilated.

Fuses and cables

When the installation work is carried out in Germany, the VDE (German Association of Electrical Engineers) regulations VDE 0100 and VDE 0105, the general guidelines of the VDEW (German Electricity Association) and the conditions of supply of the utility company concerned must be complied with. In other countries the relevant local regulations must be observed.

VDE 0560 Part 46 states that capacitor units must be suitable for a continuous RMS current of 1.3 times the current that is drawn at the sinusoidal nominal voltage and nominal frequency. If the capacitance tolerance of $1.1 \times C_N$ is also taken into account, the maximum allowable current can reach values of up to $1.38 \times I_N$. This overload capability together with the high inrush current to the capacitors must be taken into account when dimensioning fuses and cable cross sections.

Note! SCHRACK power capacitors offer a current load capacity of $1,5 - 2,2 \times I_N$ at U_N .

Table 1: Fuses and power supply cable cross sections according to VDE 0298 Part 4, installation category C

Power in kvar	400 V/50 Hz			525 V/50 Hz			690 V/50 Hz		
	Current in A	Fuse rating in A	Cross section in mm ²	Current in A	Fuse rating in A	Cross section in mm ²	Current in A	Fuse rating in A	Cross section in mm ²
2,5	3,6	10	4 × 1,5	2,7	10	4 × 1,5	2,1	10	4 × 1,5
5	7,2	10	4 × 1,5	5,5	10	4 × 1,5	4,2	10	4 × 1,5
6,25	9,0	16	4 × 2,5	6,9	10	4 × 1,5	5,2	10	4 × 1,5
7,5	10,8	16	4 × 2,5	8,2	16	4 × 2,5	6,3	10	4 × 1,5
10	14,4	20	4 × 2,5	11,0	16	4 × 2,5	8,4	16	4 × 2,5
12,5	18,0	25	4 × 4	13,7	20	4 × 2,5	10,5	16	4 × 2,5
15	21,7	35	4 × 6	16,5	25	4 × 4	12,6	20	4 × 2,5
17,5	25,3	35	4 × 6	19,2	35	4 × 6	14,6	25	4 × 4
20	28,9	50	4 × 10	22,0	35	4 × 6	16,7	25	4 × 4
25	36,1	50	4 × 10	27,5	50	4 × 10	20,9	35	4 × 6
27,5	39,7	63	4 × 16	30,2	50	4 × 10	23,0	35	4 × 6
30	43,3	63	4 × 16	33,0	50	4 × 10	25,1	35	4 × 6
31,5	45,1	63	4 × 16	34,4	50	4 × 10	26,1	50	4 × 10
37,5	54,1	80	3 × 25 / 16	41,2	63	4 × 16	31,4	50	4 × 10
40	57,7	80	3 × 25 / 16	44,0	63	4 × 16	33,5	50	4 × 10
43,75	63,1	100	3 × 35 / 16	48,1	80	3 × 25 / 16	36,6	63	4 × 16
45	65,0	100	3 × 35 / 16	49,5	80	3 × 25 / 16	37,7	63	4 × 16
50	72,2	100	3 × 35 / 16	55,0	80	3 × 25 / 16	41,8	63	4 × 16
52,5	75,8	125	3 × 50 / 25	57,7	80	3 × 25 / 16	43,9	63	4 × 16
60	86,6	125	3 × 50 / 25	66,0	100	3 × 35 / 16	50,2	80	3 × 25 / 16
62,5	90,2	125	3 × 50 / 25	68,7	100	3 × 35 / 16	52,3	80	3 × 25 / 16
67,5	97,4	160	3 × 70 / 35	74,2	125	3 × 50 / 25	56,5	80	3 × 25 / 16
68,75	99,2	160	3 × 70 / 35	75,6	125	3 × 50 / 25	57,5	80	3 × 25 / 16
75	108,3	160	3 × 70 / 35	82,5	125	3 × 50 / 25	62,8	100	3 × 35 / 16
87,5	126,3	200	3 × 95 / 50	96,2	160	3 × 70 / 35	73,2	125	3 × 50 / 25
93,75	135,3	200	3 × 95 / 50	103,1	160	3 × 70 / 35	78,4	125	3 × 50 / 25
100	144,3	200	3 × 95 / 50	110,0	160	3 × 70 / 35	83,7	125	3 × 50 / 25
112,5	162,4	250	3 × 120 / 70	123,7	200	3 × 95 / 50	94,1	160	3 × 70 / 35
125	180,4	250	3 × 120 / 70	137,5	200	3 × 95 / 50	104,6	160	3 × 70 / 35
150	216,5	315	3 × 185 / 95	165,0	250	3 × 120 / 70	125,5	200	3 × 95 / 50
175	252,6	400	2 × 3 × 95 / 50	192,5	315	3 × 185 / 95	146,4	250	3 × 120 / 70
200	288,7	400	2 × 3 × 95 / 50	219,9	315	3 × 185 / 95	167,3	250	3 × 120 / 70
225	324,8	500	2 × 3 × 120 / 70	247,4	400	2 × 3 × 95 / 50	188,3	315	3 × 185 / 95
250	360,8	500	2 × 3 × 120 / 70	274,9	400	2 × 3 × 95 / 50	209,2	315	3 × 185 / 95
275	396,9	630	2 × 3 × 185 / 95	302,4	500	2 × 3 × 120 / 70	230,1	400	2 × 3 × 95 / 50
300	433,0	630	2 × 3 × 185 / 95	329,9	500	2 × 3 × 120 / 70	251,0	400	2 × 3 × 95 / 50
350	505,2	800	2 × 3 × 240 / 120	384,9	630	2 × 3 × 185 / 95	292,9	500	2 × 3 × 120 / 70
375	541,3	800	2 × 3 × 240 / 120	412,4	630	2 × 3 × 185 / 95	313,8	500	2 × 3 × 120 / 70
400	577,4	800	2 × 3 × 240 / 120	439,9	630	2 × 3 × 185 / 95	334,7	500	2 × 3 × 120 / 70
500	721,7	1000	3 × 3 × 185 / 95	549,9	800	2 × 3 × 240 / 120	418,4	630	2 × 3 × 185 / 95

Cable connections

Each cabinet or wall-mounted enclosure must always be provided with its own power supply cable, with terminals for the L1, L2, L3, N and PE conductors. If a four-core cable is used, a connection must be made between the PE and N conductors in order to supply power to the reactive power control relay and contactor coils.

With wall-mounted systems, either a PG cable gland or a rubber grommet with a strain relief clip, depending on the power rating concerned, is provided for cable entry. In freestanding cabinets the cables enter through the floor of the enclosure.

In the case of systems with a built-in fan/filter unit, care must be taken that the opening in the floor is closed again after the cables have been connected, in order to achieve an efficient cooling effect within the cabinet.

Current transformer

A current transformer is necessary to operate power factor correction systems. This is not included in standard scope of supply, but can be supplied with the system if the requirements in the customer's installation have been clarified.

The primary current in the current transformer is dictated by the load current, the device being selected on the basis of the maximum current drawn or the rating of the power supply transformer. The circuit to the reactive power control relay is designed for a .../1 to .../5 A current transformer with a rating of 5 VA, Class 3.

If additional instruments are to be operated from the same current transformer, this must be taken into account when specifying its rating. If ammeters are installed in series with the control relay, the rating of the current transformer must be increased to suit. The internal power consumption in the control relay circuit amounts to some 1.8 VA for a current transformer with a nominal secondary current of 5 A.

Losses also occur in the current transformer wiring, and these must also be taken into account if there are long lengths of cable between the current transformer and the reactive power control relay.

Table 2: Power losses in copper conductors from a current transformer with a secondary current of 5 A.

Cross section in mm ²	Losses per metre of two-core cable in VA
2,5	0,36
4,0	0,22
6,0	0,15
10,0	0,09

Note! The current transformer must be installed in any one of the three phases so that the entire current to the loads requiring power factor correction plus the capacitor current flow through it (refer to Figs. 1–3). Terminal P1 (K) is connected to the power supply side, terminal P2 (L) to the load side.

Caution! When the circuit is broken, voltage surges occur which could destroy the current transformer. The terminals S1 (k) and S2 (l) must therefore be short-circuited before the current transformer circuit is broken.

When selecting the current transformer, the step-down ratio must be considered as well as the installed load, in order to ensure optimum functioning of the reactive power control relay.

Please ascertain the smallest and largest capacitor stages that can be switched in, as stated in the technical documentation supplied with the power factor correction system. The minimum and maximum possible current transformer step-down ratios can then be obtained from Table 3 overleaf.

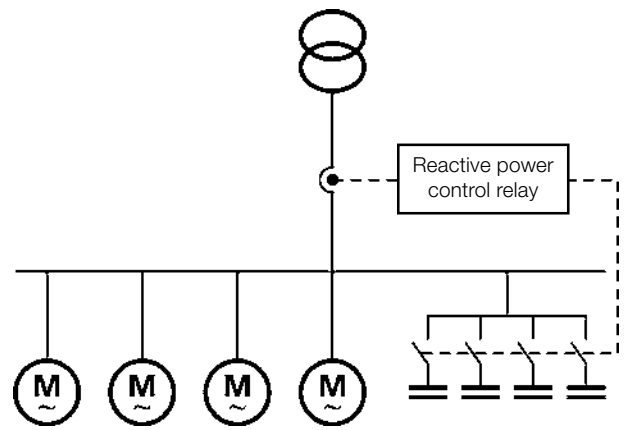

Fig. 1: Correct Current transformer installed to register load current plus capacitor current.

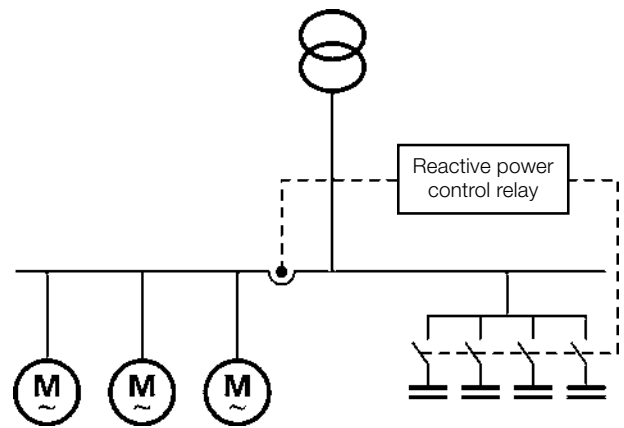

Fig. 2: Incorrect The current transformer only registers the load current: the capacitor bank is switched in but not out again. Automatic calibration of the reactive power control relay is not possible!

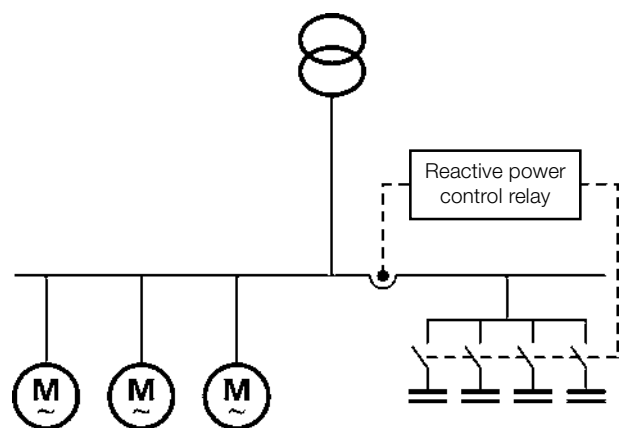

Fig. 3: Incorrect The current transformer registers zero capacitor current: the capacitor bank is not switched in. The reactive power control relay gives the message 'I = 0' (RM) or 'Undercurrent' (PQC).

Table 3: Minimum and maximum current transformer step-down ratios

Smallest stage (in kvar)	Largest stage (in kvar)	Min. and max. current transformer ratios	Min. and max. nominal primary currents for ... / 5 A transformers	Min. and max. nominal primary currents for ... / 2,5 A transformers	Min. and max. nominal primary currents for ... / 1 A transformers
2,50	2,50	1,5 ... 80	10 ... 400	5 ... 200	5 ... 80
2,50	5,00	3 ... 80	15 ... 400	10 ... 200	10 ... 80
2,50	7,50	4,5 ... 80	25 ... 400	15 ... 200	15 ... 80
2,50	10,00	6 ... 80	30 ... 400	20 ... 200	20 ... 80
2,50	15,00	9 ... 80	50 ... 400	25 ... 200	25 ... 80
2,50	20,00	12 ... 80	60 ... 400	30 ... 200	30 ... 80
5,00	5,00	3 ... 160	15 ... 800	10 ... 400	10 ... 160
5,00	10,00	6 ... 160	30 ... 800	20 ... 400	20 ... 160
5,00	15,00	9 ... 160	50 ... 800	25 ... 400	25 ... 160
5,00	20,00	12 ... 160	60 ... 800	30 ... 400	30 ... 160
5,00	30,00	18 ... 160	100 ... 800	50 ... 400	50 ... 160
5,00	40,00	24 ... 160	120 ... 800	60 ... 400	60 ... 160
6,25	6,25	3,75 ... 160	20 ... 1000	10 ... 500	10 ... 160
6,25	12,50	7,5 ... 160	40 ... 1000	20 ... 500	20 ... 160
6,25	18,75	11,3 ... 160	60 ... 1000	30 ... 500	30 ... 160
6,25	25,00	15 ... 160	75 ... 1000	40 ... 500	40 ... 160
6,25	37,50	22,5 ... 160	120 ... 1000	60 ... 500	60 ... 160
6,25	50,00	30 ... 160	150 ... 1000	75 ... 500	75 ... 160
7,50	7,50	4,5 ... 240	25 ... 1200	15 ... 600	15 ... 240
7,50	15,00	9 ... 240	50 ... 1200	25 ... 600	25 ... 240
7,50	22,50	13,5 ... 240	75 ... 1200	40 ... 600	40 ... 240
7,50	30,00	18 ... 240	100 ... 1200	50 ... 600	50 ... 240
7,50	45,00	27 ... 240	150 ... 1200	75 ... 600	75 ... 240
7,50	60,00	36 ... 240	200 ... 1200	100 ... 600	100 ... 240
10,00	10,00	6 ... 320	30 ... 1600	20 ... 800	20 ... 320
10,00	20,00	12 ... 320	60 ... 1600	30 ... 800	30 ... 320
10,00	30,00	18 ... 320	100 ... 1600	50 ... 800	50 ... 320
10,00	40,00	24 ... 320	120 ... 1600	60 ... 800	60 ... 320
10,00	60,00	36 ... 320	200 ... 1600	100 ... 800	100 ... 320
10,00	80,00	48 ... 320	250 ... 1600	120 ... 800	120 ... 320
12,50	12,50	7,5 ... 400	40 ... 2000	20 ... 1000	20 ... 400
12,50	25,00	15 ... 400	75 ... 2000	40 ... 1000	40 ... 400
12,50	37,50	22,5 ... 400	120 ... 2000	60 ... 1000	60 ... 400
12,50	50,00	30 ... 400	150 ... 2000	75 ... 1000	75 ... 400
12,50	75,00	45 ... 400	250 ... 2000	120 ... 1000	120 ... 400
12,50	100,00	60 ... 400	300 ... 2000	150 ... 1000	150 ... 400
15,00	15,00	9 ... 480	50 ... 2400	25 ... 1200	25 ... 480
15,00	30,00	18 ... 480	100 ... 2400	50 ... 1200	50 ... 480
15,00	45,00	27 ... 480	150 ... 2400	75 ... 1200	75 ... 480
15,00	60,00	36 ... 480	200 ... 2400	100 ... 1200	100 ... 480
15,00	90,00	54 ... 480	300 ... 2400	150 ... 1200	150 ... 480
25,00	25,00	15 ... 800	75 ... 4000	40 ... 2000	40 ... 800
25,00	50,00	30 ... 800	150 ... 4000	75 ... 2000	75 ... 800
25,00	75,00	45 ... 800	250 ... 4000	120 ... 2000	120 ... 800
25,00	100,00	60 ... 800	300 ... 4000	150 ... 2000	150 ... 800
50,00	50,00	30 ... 1600	150 ... 8000	75 ... 4000	75 ... 1600
50,00	100,00	60 ... 1600	300 ... 8000	150 ... 4000	150 ... 1600

Reactive power control relays PQC

To avoid reactive power penalty charges, the reactive power control relay must be set, as a minimum requirement, at the target value of $\cos \varphi$ required by the local utility company. The basic factory settings represent the most frequently specified $\cos \varphi$ requirement. A detailed description of the possible control characteristics is given in the operating manual for the reactive power control relay concerned.

Automatic detection of connection, switching sequence and response current.

The reactive power control relays automatically detect the connection (phase angle), switching sequence and the response current (c/k).

These instruments have a factory setting of 0.92 for the target power factor. If it is desired to operate at this power factor, no further setting is necessary when commissioning the reactive power control relay.

When first started up, the reactive power control relay carries out the connection and response current detection process, and is then ready to operate.

Note! As the control relays always adapt to the installed supply system configuration, it can be necessary in individual cases to enter the required parameters manually.

When the low voltage supply system is fed by several transformers arranged in parallel, the capacitor current is distributed between all the transformers. If this current is not measured via summation current transformers, the change in current measurable by the control relay when the capacitor stages are switched in is too small, which would result in too low a response current during automatic c/k detection. In cases of this type and also in networks with continual load changes (e.g. gang saws, automatic presses, welding lines and drop forges with switching periods < 2 seconds), the c/k value has to be entered manually.

No-volt release

The reactive power control relays are provided with a no-volt release function. This prevents all the capacitor stages being switched in simultaneously when power is restored following an outage.

The contactors are released on power failure, and are then energized again to suit requirements. Standard systems are wired so that the control voltage for the contactors is tapped from the voltage supply to the control relay. It is strongly advised not to use an external control voltage, since with this the no-volt release would no longer function, with the possibility that damage might be caused not only to the power factor correction system but also to other components in the electrical installation.

Overcurrent trip

The PQC control relays have the capability of determining the ratio between the RMS current and the fundamental current in the capacitor. If this ratio exceeds a value set at the control relay (factory default setting 1.2) for at least one minute, on account of system harmonics and the consequent amplification they produce due to resonance, all the capacitor stages are switched out.

This trip can be evaluated via the alarm management function (please refer to the PQC operating manual).

Commissioning

Before the AC supply voltage is applied to the system, a visual check should be carried out by a qualified technician to verify that no equipment or connections have worked loose during transport. If this has happened, the components and connections concerned must be correctly tightened again. Please verify that the connections to the current transformer are made at terminals S1 and S2 (current transformers are not included in the standard scope of supply).

Powering up

RM reactive power control relays start the calibration procedure automatically, switching the capacitor stages in and out in succession. PQC reactive power control relays display the Start screen and wait for the operator to initiate start-up by pressing the appropriate key. Please refer to the operating manual supplied with the instrument for further information.

The operating manual describes in detail how to change the default target power factor or other parameters, should this be necessary.

If the control relay does not react as described here, please systematically check through the individual points given in the Troubleshooting section.

Switching off the voltage

If the voltage is to be removed from the power factor correction system, switch the control relay over to manual mode and then switch out all the capacitor stages. This enables the main fuses to be removed or the fuse switch-disconnector to be switched off under no-load conditions.

Operation and maintenance

Power factor correction systems operate automatically and for a long time without any maintenance. Carrying out a regular inspection at least once a year can, however, prevent reactive power penalty charges suddenly being incurred or the correction system being damaged by an undetected fault.

Alarm signal

All SCHRACK reactive power control relays are provided with a built-in alarm contact (terminals a and b), which can be connected to an alarm system. If the set power factor is not achieved, an alarm signal is given.

The operating manual for the control relay contains more information on the types of alarm and the adjustment of their set points.

Fuses

Low voltage, high breaking capacity fuses undergo an ageing process when carrying the high switched currents associated with capacitors. They should therefore be inspected at least once per year. We recommend replacing the fuse links after ten years at the latest.

Contactors

Contactors specially designed to switch capacitors in and out are always used in SCHRACK systems. When replacing contactors, please therefore ensure that only the capacitor-switching type is fitted.

The contacts of capacitor switching contactors have a particularly demanding duty. They are tested for 80,000 switching cycles and must be completely replaced once this number has been reached. If the power factor correction system has a control relay with a switching cycle counter (such as the PQC), a separate message is given for each stage after 80,000 switching cycles (factory default setting, which can, however, be changed) to inform the operator that contactor replacement is due. The momentary counter readings can be accessed via the control relay:

Main menu -> Info/status -> Switch cycle diagram.

Please refer to the control relay operating manual.

Note! Wear and tear of the switching contacts has an adverse effect on the service life of the capacitors!

Temperature trip

Power factor correction systems have a built-in temperature switch interlocked with the control system. If a build-up of heat causes the interior temperature of the enclosure to rise above $60\text{ °C} \pm 3\text{ K}$, the switch shuts the system down by cutting off the power supply to the control relay.

Note! The user is alerted via the alarm contact on the control relay. The temperature trip has to be reset manually. If the system comprises several cabinets, all their temperature switches are connected in series.

Discharge resistors

The capacitors have discharge resistors permanently integrated at their terminals for the safety of personnel, in compliance with VDE (German Association of Electrical Engineers) regulations. In addition to their safety function, they are also indispensable for problem-free operation of the system and must on no account be removed. Attention must be paid to this point particularly when capacitors are replaced!

Detuned systems

Detuned systems have been specially designed for operation in networks that are highly distorted by harmonics. The filter circuit chokes have a strong self-heating tendency and can reach temperatures in excess of 100 °C . They are, however, designed for these temperatures and have a built-in temperature switch. This switches off the contactor associated with the choke for a long enough time until the latter has cooled down again.

Ventilation / heat dissipation

For correct ventilation ensure that there is no hindrance to the flow of air at the enclosure inlet or outlet. Also ensure that the bottom of the cabinet is closed, i.e. the area around the incoming cables, so that the cooling air is not drawn in or vented through undefined apertures.

The air inlet and outlet must be cleaned regularly, the frequency depending on how polluted the air is at the installation site.

Fan

Power factor correction systems with high power losses are equipped with fans controlled by thermostats, which should be set at 30 °C . The power for the fan motor is supplied via the control circuit fuse.

Capacitors

The capacitors must be checked visually during the annual inspection for any mechanical changes. Any variation in capacitance or distortion by harmonics can be inferred from the operating currents measured.

General

Please ensure that the system is kept clean at all times, if necessary having it cleaned by skilled personnel. During the annual inspection the system must be given a visual check by an electrician to detect any deficiencies (worn electrical contacts, evidence of overheating, etc.).

Troubleshooting

No reaction, no display at all on control relay

- Cause: No power at control relay
- Action: Check voltage at terminals L1, L2, L3 and N.
Check control circuit fuse.
Check whether temperature switch has tripped.

Contactors do not close even though the capacitor stage display on the control relay indicates switched-in stages.

- Cause: No control voltage or no neutral for contactor.
If four-wire supply, no jumper fitted between N and PE.
- Action: Check control fuses and cabling.

Contactors do not close. The display indicates 'cap' in the RM... control relay display, or 'CA' in the PQC display, even though the load is inductive.

- Cause: Current transformer installed in spur to capacitors.
- Action: Install current transformer in the main power supply line, as shown in Fig. 1.

The message 'V=0' flashes in the RM... control relay display, or 'Undervoltage' in the PQC display.

- Cause: No voltage or wrong voltage connected to the control relay for measurement.
- Action: Check whether the voltage being measured at the control relay is at the correct level.

The message 'I=0' flashes in the RM... control relay display, or 'Undercurrent' in the PQC display.

- Cause: No current or too low a current in the current transformer circuit.
- Action: Check current transformer (I_{min} 0.02 A) and cabling.

The message 'C = 0' flashes in the in the RM... control relay display, or 'Stages not identified' in the PQC display.

- Cause: The control relay has not detected any capacitances despite having carried out the calibration procedure.
No capacitor current is registered by the current transformer: see Fig. 2.
- Action: Install current transformer in the main power supply line as shown in Fig. 1.

Control relay switches all stages in, but does not switch them out when the load reduces.

- Cause: Current transformer registers only the load current without the capacitor current.
- Action: Install current transformer in main power supply line as shown in Fig. 1.

The reactive power control relay does not terminate the automatic calibration procedure.

- Cause 1: Fault in control circuit (contactors not closing).
- Action: Check control circuit fuse and cabling.
- Cause 2: Highly unstable network (wide cos φ fluctuations).
- Action: Wait for stable network conditions or enter c/k and type of connection manually (see control relay operating manual).
- Cause 3: No current in current transformer circuit.
- Action: Check current transformer and cabling.

Reactive current consumption too high even though all capacitors are switched in.

- Cause 1: Capacitor power rating inadequate.
- Action: Check whether all contactors have closed.
Check fuses and capacitor currents.
Review the calculation of the required capacitor rating.
- Cause 2: Spur to capacitors is connected before the instrument transformer for the utility company's meter.
- Action: Relocate the connection.

Maintenance recommendations:

Components	Review	Replacement / Repair
Switch cabinet	annually	In case of damage
Cable entry	annually	In case of damage
Busbar connection cable entry	annually	In case of damage
(NH) fuse links/cover	annually	In case of defect/after 10 years at the latest
Capacitors	annually	In case of power loss or defect
Choke	annually	In case of power loss or defect
Contactors	annually	80,000 switching cycles or after 6-8 years at the latest
Discharge resistors/chokes/devices	annually	In case of damage
Mechanical and electrical connections	annually	In case of damage
Fan	annually	In case of damage
Filter mat	annually	Recommended annually, more frequently if necessary
Power factor controller	annually	If necessary software update on demand

EU-KONFORMITÄTSERKLÄRUNG

EU-DECLARATION OF CONFORMITY

Name/Anschrift des
Ausstellers:
Issuer's name and
address:

Schrack Technik GmbH
Seybelgasse 13
A-1235 WIEN / Vienna
ÖSTERREICH / AUSTRIA

Produktbezeichnung:
Product:

Blindleistungs– Regelanlagen, eingebaut in
Stahlblechgehäuse /
Power Factor Control System

LSFC, LSK, LKNS

Typenbezeichnung:
Type designation:

FR341xxxxx

Das bezeichnete Produkt erfüllt die Bestimmungen der Richtlinie:
The designated product is in conformity with the European Directive:

2014/30/EU - EMV-Richtlinie / EMC directive

2014/35/EU - Niederspannungsrichtlinie / Low voltage directive

Die Übereinstimmung des bezeichneten Produktes mit den Anforderungen der Richtlinie wird durch die technische Dokumentation sowie die vollständige Einhaltung folgender Normen nachgewiesen:

The technical documentation and full compliance with the standards listed below proves the conformity of the product with the requirements of the above-mentioned EC Directive:

EN 61000-6-3: 2007-09

EN 61000-6-4: 2007-09

EN 61000-6-1: 2007-10

EN 61000-6-2: 2006-03

EN 61439-1: 2010-06

EN 61439-2: 2010-06

EN 61921: 2004-02

EN 60 831-1: 2014-11

EN 60 831-2: 2014-11



.....
Josef Gattermayer
Bereichsleiter Produktmanagement & Einkauf
Head of product management & purchasing



.....
Aram Zeitlinger
Produktmanager
Product manager

Wien / Vienna, April 2017

Control cabinet enclosures

The maximum ambient temperature of power factor correction systems must not exceed 40 °C (EN 61439-1, VDE 0660 600-1, -2).

The enclosures must have adequate vents in the door and roof in order for the heat from power losses to dissipate.

Many power factor correction systems require forced ventilation with an electric fan. Cabinets with IP54 ingress protection, even those not housing detuned systems, must in most cases be fitted with a fan/filter unit.

Capacitors and combined capacitor/reactor modules of the type C are designed for various widths and depths of cabinet:

Type	min. width of the cabinet	min. depth of the cabinet
C64	600 mm	400 mm
C65	600 mm	500 mm
C66	600 mm	600 mm
C84	800 mm	400 mm
C85	800 mm	500 mm
C86	800 mm	600 mm

The C Modules are inserted in the cabinet on mounting rails and secured with the screws supplied. Cabinets with a greater depth than the minimum value have several fixing positions on the rails. When a fixing position at the rear is used, the fixing lugs at the front must be bent outwards. At the mounting rails there are also fixing options for the control circuit cable trunking. The lugs needed for this purpose can be bent outwards.

The module rails for the different types of cabinets need to be ordered separately.

When choosing the type of enclosure, the weight of the modules must be taken into consideration, to ensure that a cabinet of sufficient stability is selected.

Power loss

The total power loss in the modules, i.e. in the capacitors, reactors (chokes) if fitted, fuses, contactors and wiring is estimated as follows:

Modules or power factor correction systems without detuning max. 2.5 W / kVAr

Detuned modules or power factor correction systems max. 8.5 W / kVAr

The cabinet must be designed so that the heat from the power loss can be dissipated and the temperature of the enclosure does not exceed 60 °C.

Construction of power factor correction systems using C Modules

A modular power factor correction system consists of the following components:

- Enclosure
- Complete power factor control relay package (STR-...)
- Mounting plate for the control unit
- Capacitor module(s) or capacitor/reactor module(s) including control unit and connecting wires (part of the modules)
- Mounting rail sets for modules, also needed for the control unit mounting plate
- Fan unit if required

Power factor correction systems with several modules are assembled from the bottom up. This sequence also applies for the wiring of the contactor controls.

From the control unit terminal strip, a cable (already fitted in the case of control relay complete packages) or the appropriate number of single conductors must be run to the control relay, and the control wires (supplied with the modules) must be run to the capacitor module(s). If several contactors are to be switched in parallel, this is achieved by fitting jumpers across the module connectors or by running single conductors from the control unit terminal strip to the capacitor module(s).

With this type of arrangement, as shown below, it is easier to carry out an extension at a later date.

Slot 0 is left empty and serves as the cable terminal compartment. If required, audio frequency rejector circuits can also be installed here.

The first module is housed in slot 1. If, for example, only 3 modules are installed, slot 4 remains empty. An extension at a later date is possible with little effort. Provided that their cross sections have been sufficiently dimensioned for the extension, the power supply cables remain unchanged.

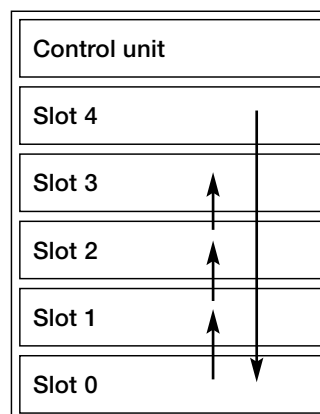

Power Factor Correction Systems – Assembly Instructions

Complete power factor control relay packages (STR-...)

STR modules are available with 6- or 12-stage power factor control relays. The module contains the power factor control relay (RM 2106, RM 2112 or PQC), the associated control unit terminal strip complete with the control circuit fuse and temperature switch, and the control relay cable (already fitted).

At 60 °C +/- 3 K, the temperature trip switches off the capacitor contactors via the control relay. (Note: The temperature trip must be reset manually afterwards.)

The control unit terminal strip and the temperature switch must be fitted on the mounting plate at their specified locations, using the fasteners supplied. The temperature switch mounting flange must be adequately earthed (this is assured when the switch is fitted as recommended).

For systems to be extended, 12-stage control unit terminal strips, without a control circuit fuse but with a temperature switch, are available.

Note! When connecting extension units to a basic system, the wire jumper from T1 to T2 on the basic system's control unit terminal strip must be removed. If there is already an extension unit connected to the basic system, the plug-in jumper from T2 to T3 on that first extension unit's terminal strip must be removed. If this is not done, the temperature trip function of the extension unit will not be operational.

In systems equipped with a fan, the associated temperature controller is mounted in the upper section of the enclosure, with its set point adjusted to 30 °C.

The supply side of the control circuit fuses must be connected directly to the external power supply by a short-circuit-proof stranded cable.

Capacitor modules, capacitor/reactor (choke) modules

The capacitor modules are equipped with low-loss capacitors (encased single capacitors, connected as banks with discharge resistors, discharge down to 75 V or less in 60 s), contactors and a busbar system with size NH00 fuses.

With the capacitor/reactor modules, there is an additional reactor connected in series with the capacitors. The power supply line is connected to the busbars, which are angled at 90° for this purpose. If it is desired to connect the supply line vertically, the CU-AW-1 bus connection bracket must be ordered as a separate accessory.

The cables of the contactor coils are connected to one (1–3 stages) or two (4–7 stages) 4-pole pin-type plug(s). The connection of the capacitor modules to the control circuit terminal strip is means of the prefabricated cables with connectors supplied as accessories with the modules.

By means of these connections, or by connecting contactor coils in parallel using plug-in jumpers at the capacitor module connectors, several contactors can be controlled jointly in order to switch in a number of capacitor banks simultaneously. This is necessary when stages with high corrective power are called for.

If each stage has the same corrective power, the switching sequence is described as 1:1:1... . If subsequent stages are twice as large as the first, the switching sequence would be 1:2:2....

The switching sequence 1:1:2... indicates that the first two stages each have, for example, 25 kvar and all further stages have 50 kvar. Power factor control relays detect these switching sequences automatically, but they can also be entered manually.

If the minimum response current (c/k) is set manually, the minimum stage corrective power (i.e. valency 1) and the current transformer ratio must be taken into account. When a summation current transformer is used, the sum of all currents of the main transformers must be taken into consideration when setting the value of c/k.

Installation of power factor correction systems for supply voltages > 400 V

When it is planned to use modules or power factor correction systems for a supply voltage > 400 V, an appropriately rated control transformer must be installed for the control circuit (contactors, fans and possibly power factor control relay).

The coils of the contactors are designed for a power supply of 230 V/50Hz and 240 V/60 Hz!

At voltages of 500 V or more, a motor circuit breaker must be fitted at the control unit terminal instead of the cylindrical fuses (10 × 38 mm) as overcurrent protection for the control transformer, since fuses are only approved up to 500 V!).

Control transformers with various power ratings and primary voltages up to 690 V are available as accessories.

Key to the components

- C1... Capacitor stage
- G1 Fan/filter unit
- F1, F2 Fuses, size NH00
- F01 Control circuit fuse
- Q1... Capacitor contactors
- R1... Reactors
- K1 Power factor control relay
- S1 Temperature switch (internal cabinet temperature, 60 °C)
- K2 Thermostat to switch the fan/filter unit on and off, 30 °C
- X1 Control unit terminal strip
- X1.1 ... Terminals on the modules

Contactor circuit diagram

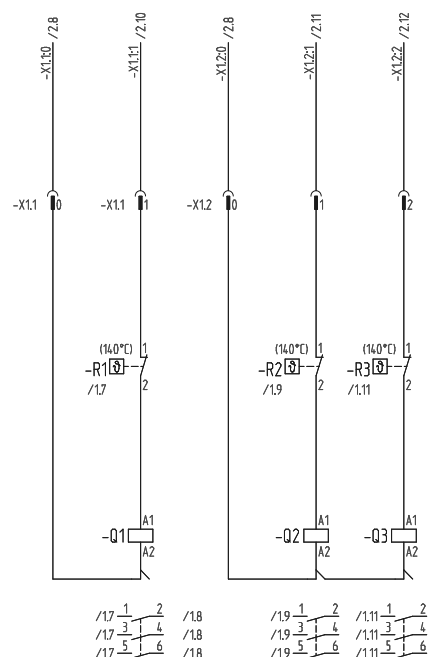

Power Factor Correction Systems – Assembly Instructions

Circuit diagram for a detuned power factor correction system with 3 stages and a 6-stage reactive power control relay (A key to the components is given on page 10)

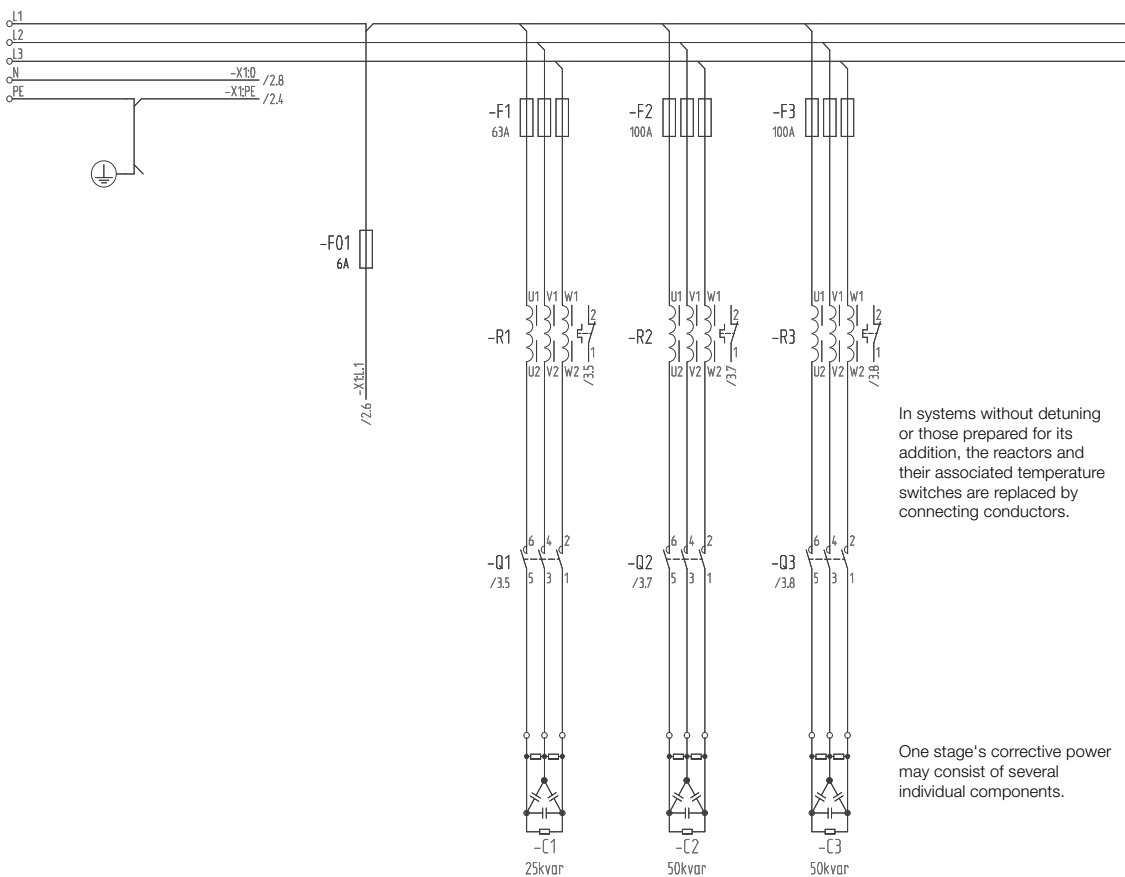

Circuit diagram of control unit (A key to the components is given on page 10)

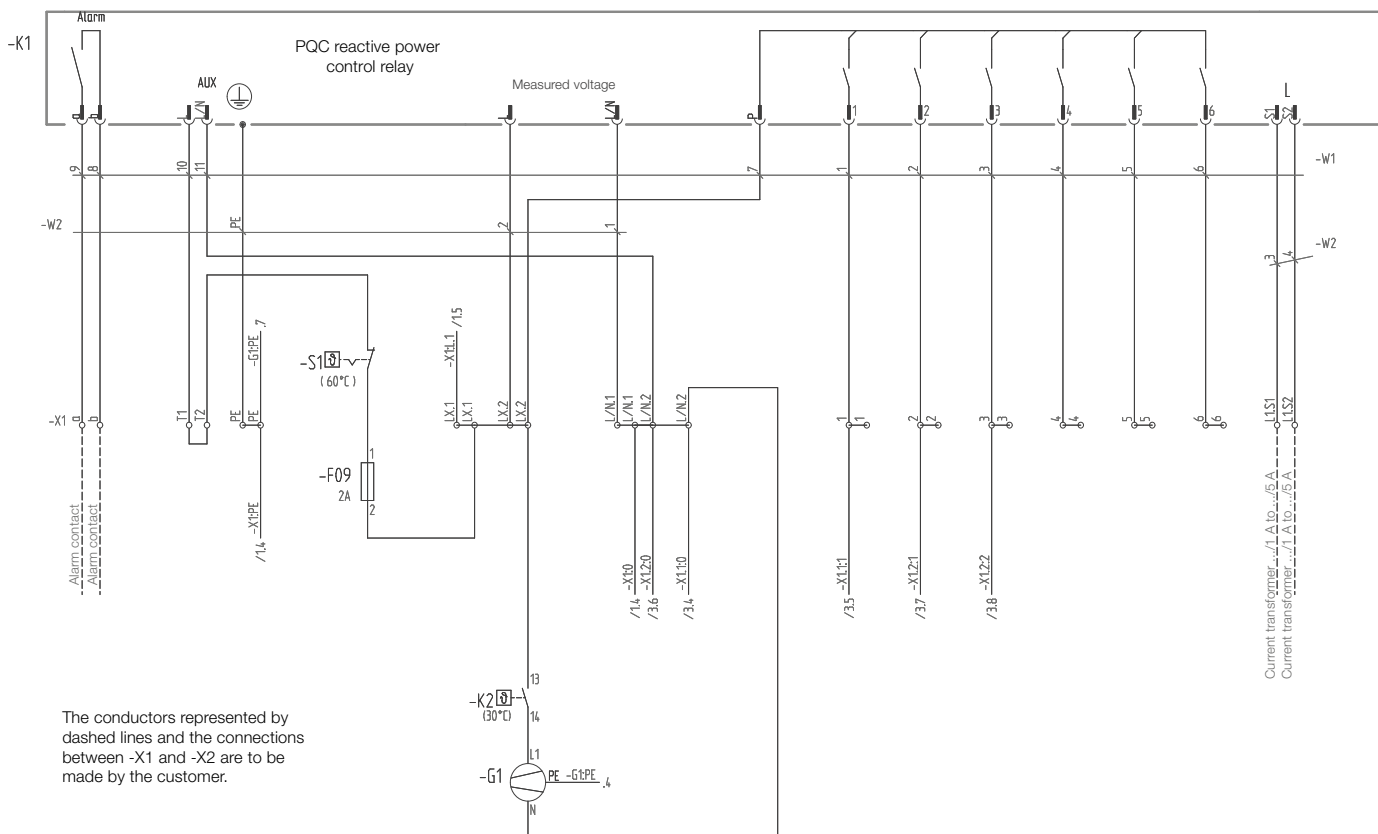

THE COMPANY

HEADQUARTERS

SCHRACK TECHNIK GMBH

Seybelgasse 13, 1230 Vienna
PHONE +43(0)1/866 85-5900
FAX +43(0)1/866 85-98800
E-MAIL info@schrack.at

SCHRACK SUBSIDIARIES

BELGIUM

SCHRACK TECHNIK B.V.B.A
Twaalfpostelenstraat 14
BE-9051 St-Denijs-Westrem
PHONE +32 9/384 79 92
FAX +32 9/384 87 69
E-MAIL info@schrack.be

BOSNIA-HERZEGOVINA

SCHRACK TECHNIK BH D.O.O.
Put za aluminijski kombinat bb
BH-88000 Mostar
PHONE +387/36 352 895
FAX +387/36 352 893
E-MAIL schrack@schrack.ba

BULGARIA

SCHRACK TECHNIK EOOD
Prof. Tsvetan Lazarov 162
Druzhiba - 2
BG-1582 Sofia
PHONE +359 2/890 79 13
FAX +359 2/890 79 30
E-MAIL sofia@schrack.bg

CROATIA

SCHRACK TECHNIK D.O.O.
Zavrtnica 17
HR-10000 Zagreb
PHONE +385 1/605 55 00
FAX +385 1/605 55 66
E-MAIL schrack@schrack.hr

CZECH REPUBLIC

SCHRACK TECHNIK SPOL. SR.O.
Dolnomecholupska 2
CZ-10200 Praha 10 – Hostivar
PHONE +420 (0)2/810 08 264
FAX +420 (0)2/810 08 462
E-MAIL praha@schrack.cz

HUNGARY

SCHRACK TECHNIK KFT.
Vidor u. 5
H-1172 Budapest
PHONE +36 1/253 14 01
FAX +36 1/253 14 91
E-MAIL schrack@schrack.hu

GERMANY

SCHRACK TECHNIK GMBH
Thomas-Wimmer-Ring 17
D-80539 Munich
PHONE +49 89/999 533 900
FAX +49 89/999 533 902
E-MAIL info@schrack-technik.de

POLAND

SCHRACK TECHNIK POLSKA
SP.ZO.O.
ul. Staniewicka 5
PL-03-310 Warszawa
PHONE +48 22/205 31 00
FAX +48 22/205 31 01
E-MAIL kontakt@schrack.pl

ROMANIA

SCHRACK TECHNIK SRL
B-dul Iuliu Maniu nr 453-457, sect. 6
RO-061101 Bucharest
PHONE +40 21/317 02 35 42
FAX +40 21/317 02 62
E-MAIL bucuresti@schrack.ro

SERBIA

SCHRACK TECHNIK D.O.O.
Bulevar Peka Dapčevića 42
RS-11000 Beograd
PHONE +38 1/11 309 2600
FAX +38 1/11 309 2620
E-MAIL office@schrack.rs

SLOVAKIA

SCHRACK TECHNIK S.R.O.
Ivanská cesta 10/C
SK-82104 Bratislava
PHONE +421 (02)/491 081 01
FAX +421 (02)/491 081 99
E-MAIL info@schrack.sk

SLOVENIA

SCHRACK TECHNIK D.O.O.
Pameče 175
SLO-2380 Slovenj Gradec
PHONE +38 6/2 883 92 00
FAX +38 6/2 884 34 71
E-MAIL schrack.sg@schrack.si



WWW.SCHRACK.COM

